

Note:
If the EMMC current exceeds 300MA, please use the U4001

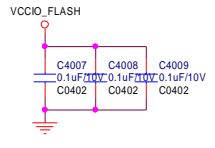

Note:
Reserve PAD for Update.

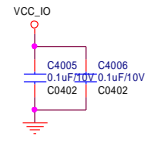
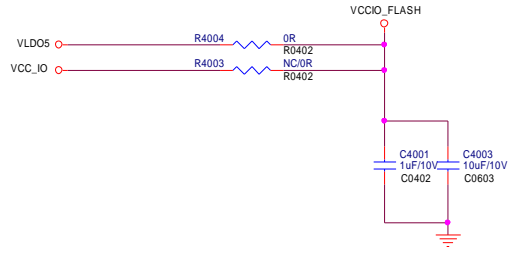
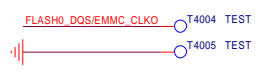

Default
1.1V

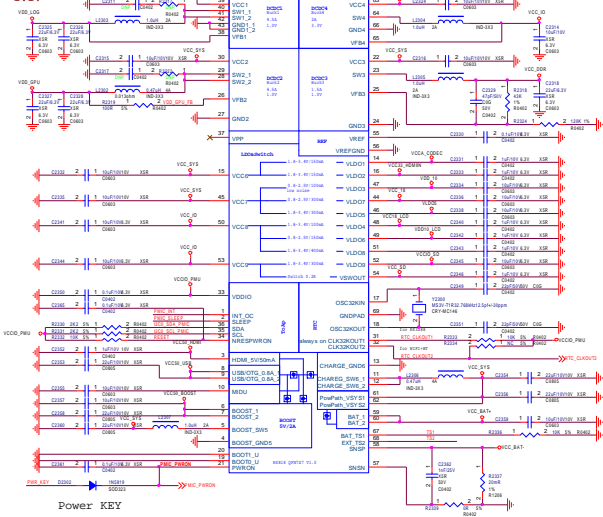

Power KEY

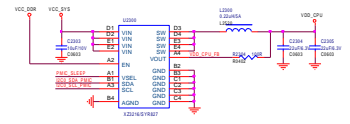

- VCC1.1V
- VCC1.8V
- VCC3.0V
- VCC5.0V
- VCC1.8V
- VCC3.0V
- VCC5.0V

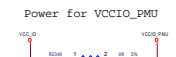
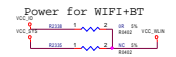
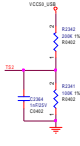

葡萄雨技术 www.graperain.cn

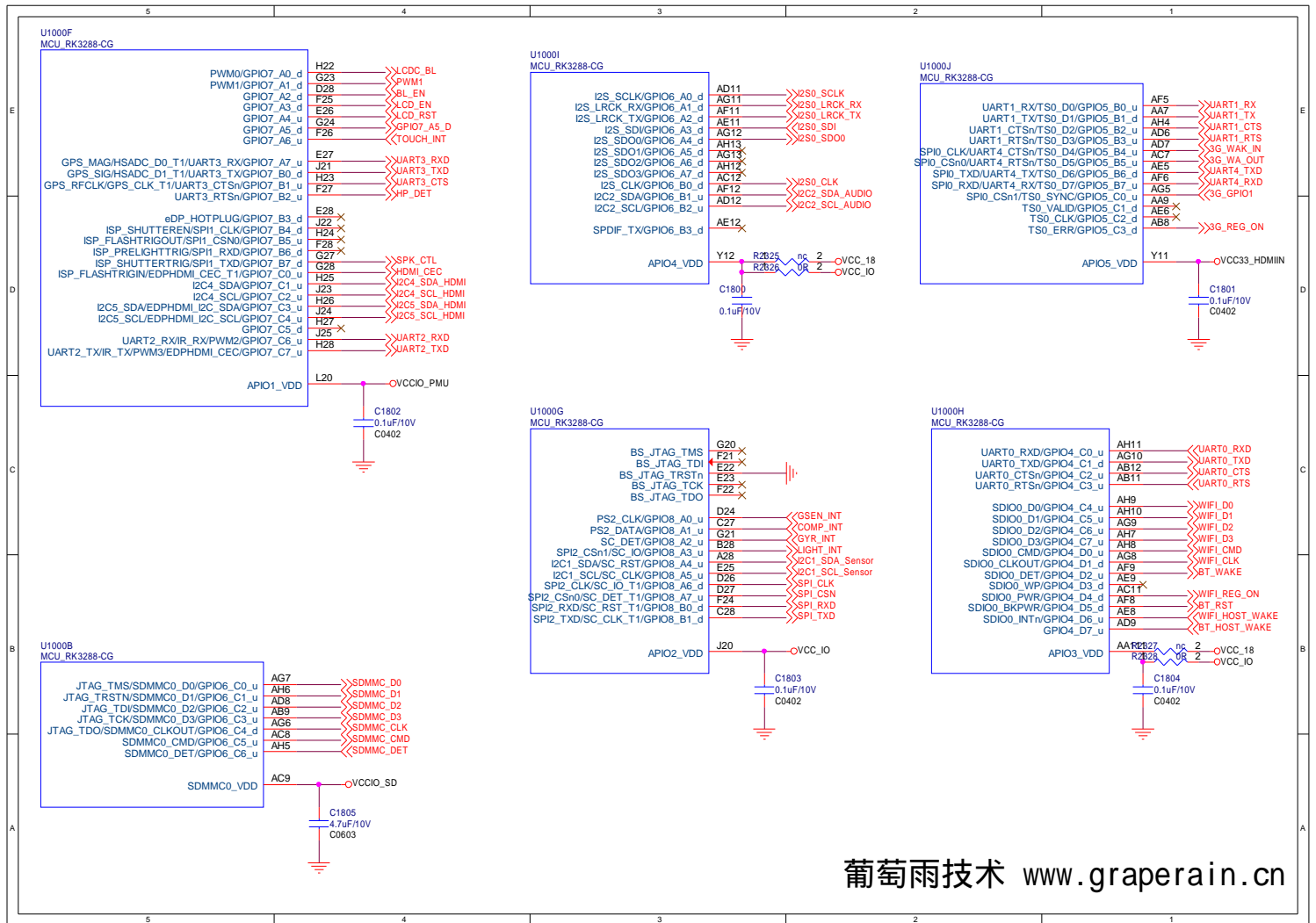

葡萄雨技术 www.graperain.cn

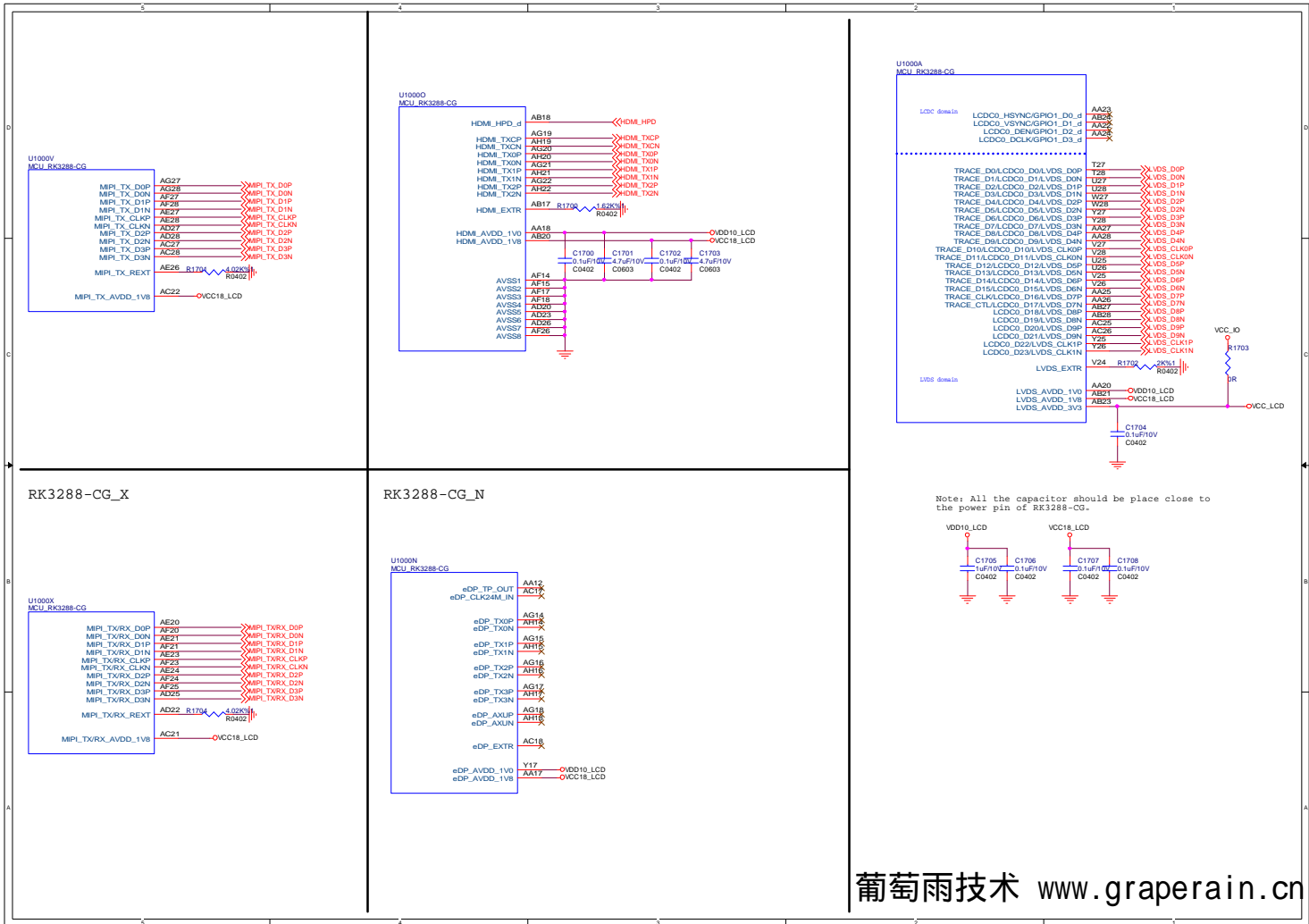

葡萄雨技术 www.graperain.cn

RK3288-CG_C

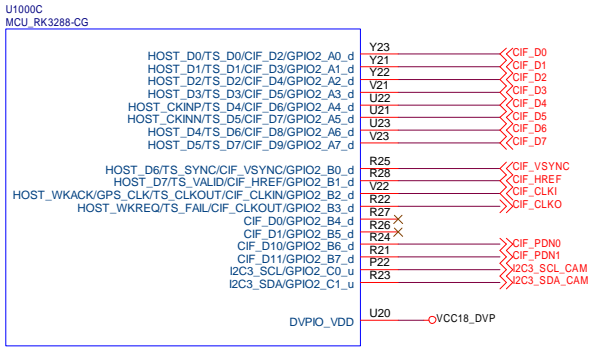

Note: All the capacitor should be place close to the power pin of RK3288-CG.

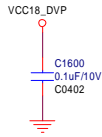

RK3288-CG_W

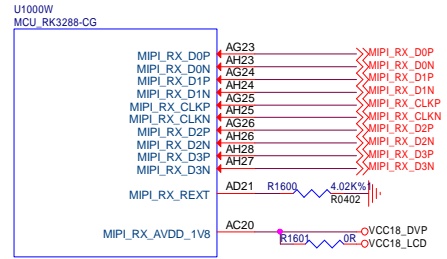

葡萄雨技术 www.graperain.cn

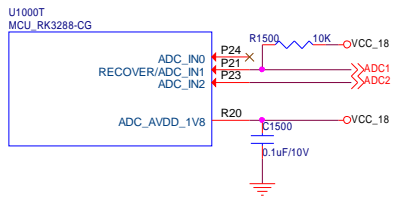

葡萄雨技术 www.graperain.cn

RK3288-CG_E

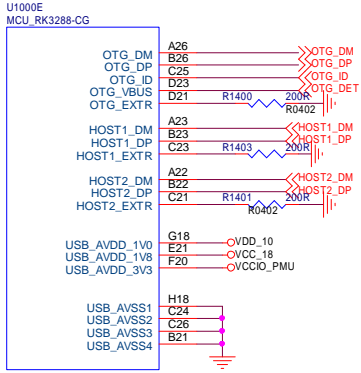

Note2: USB_HOST1 don't support USB1.1;

Note1: All the capacitor should be place close to the power pin of RK3288.

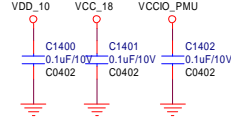

RK3288_U

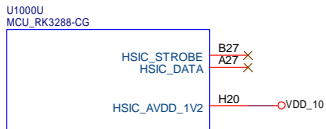

葡萄雨技术 www.graperain.cn

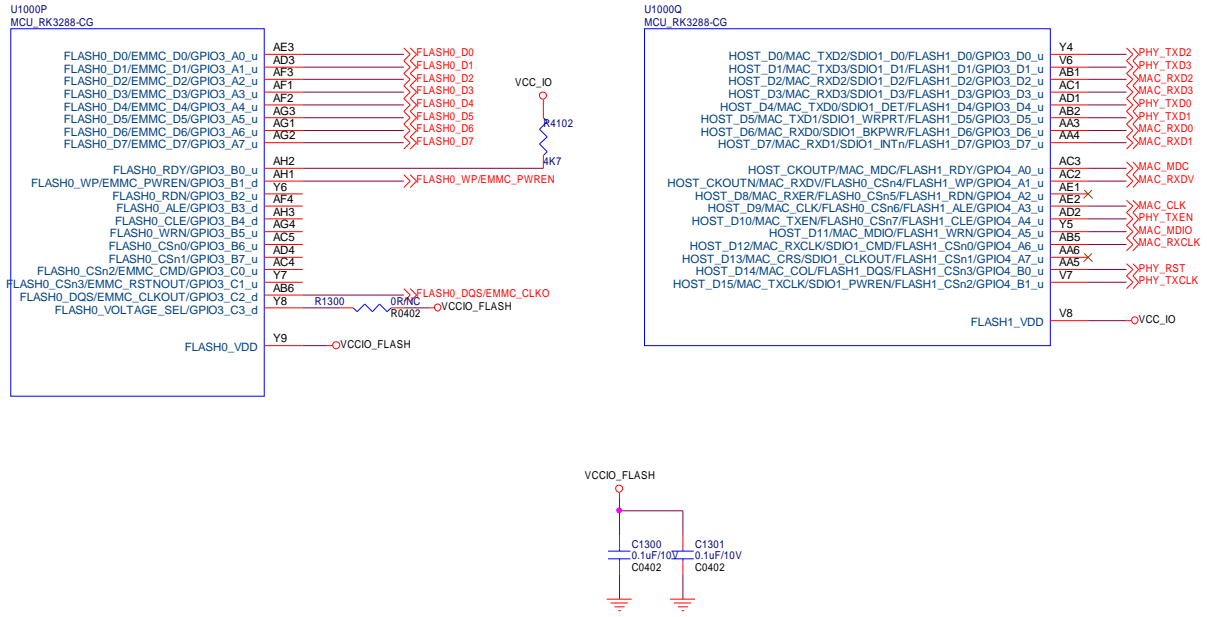

葡萄雨技术 www.graperain.cn

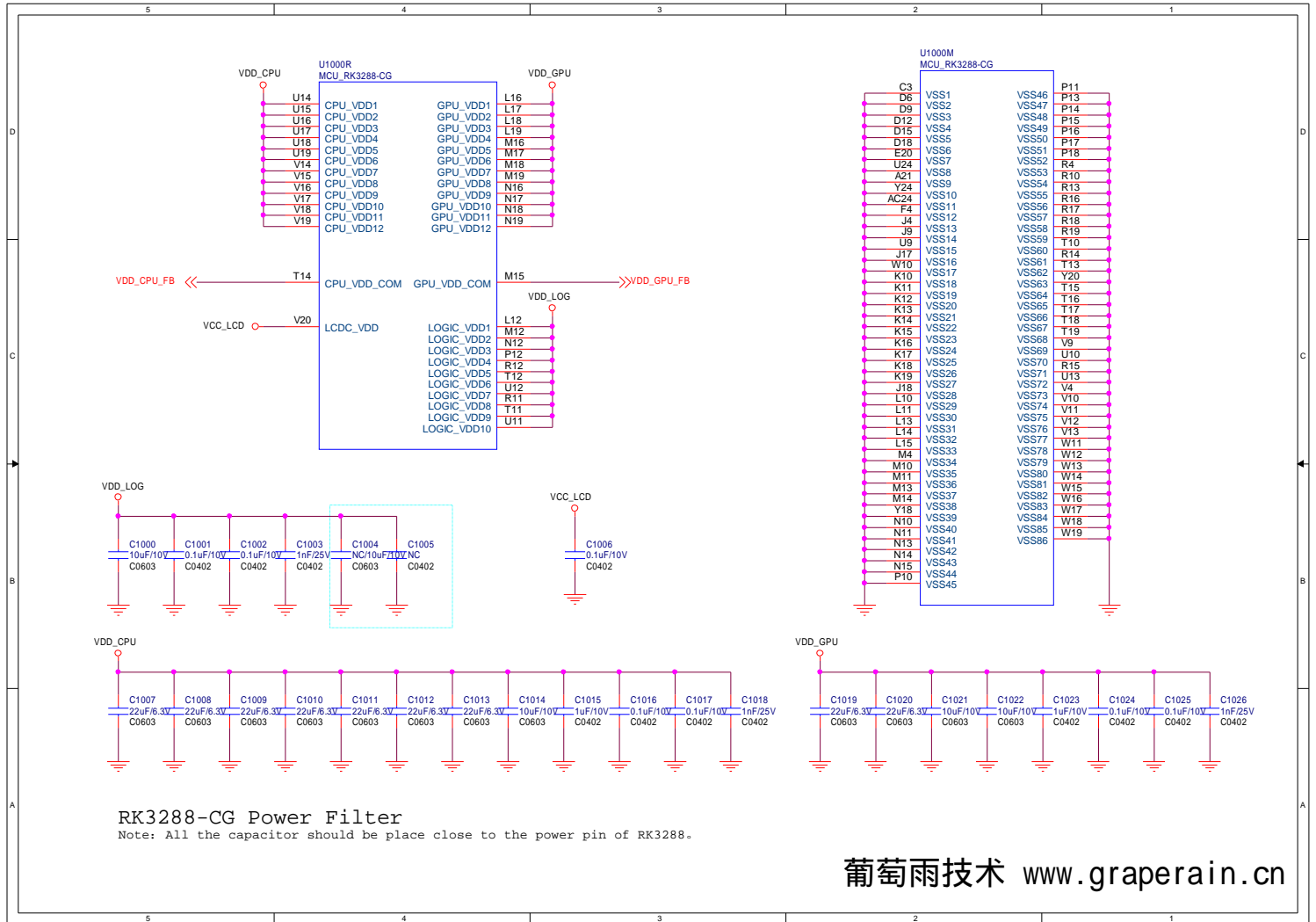

葡萄雨技术 www.graperain.cn

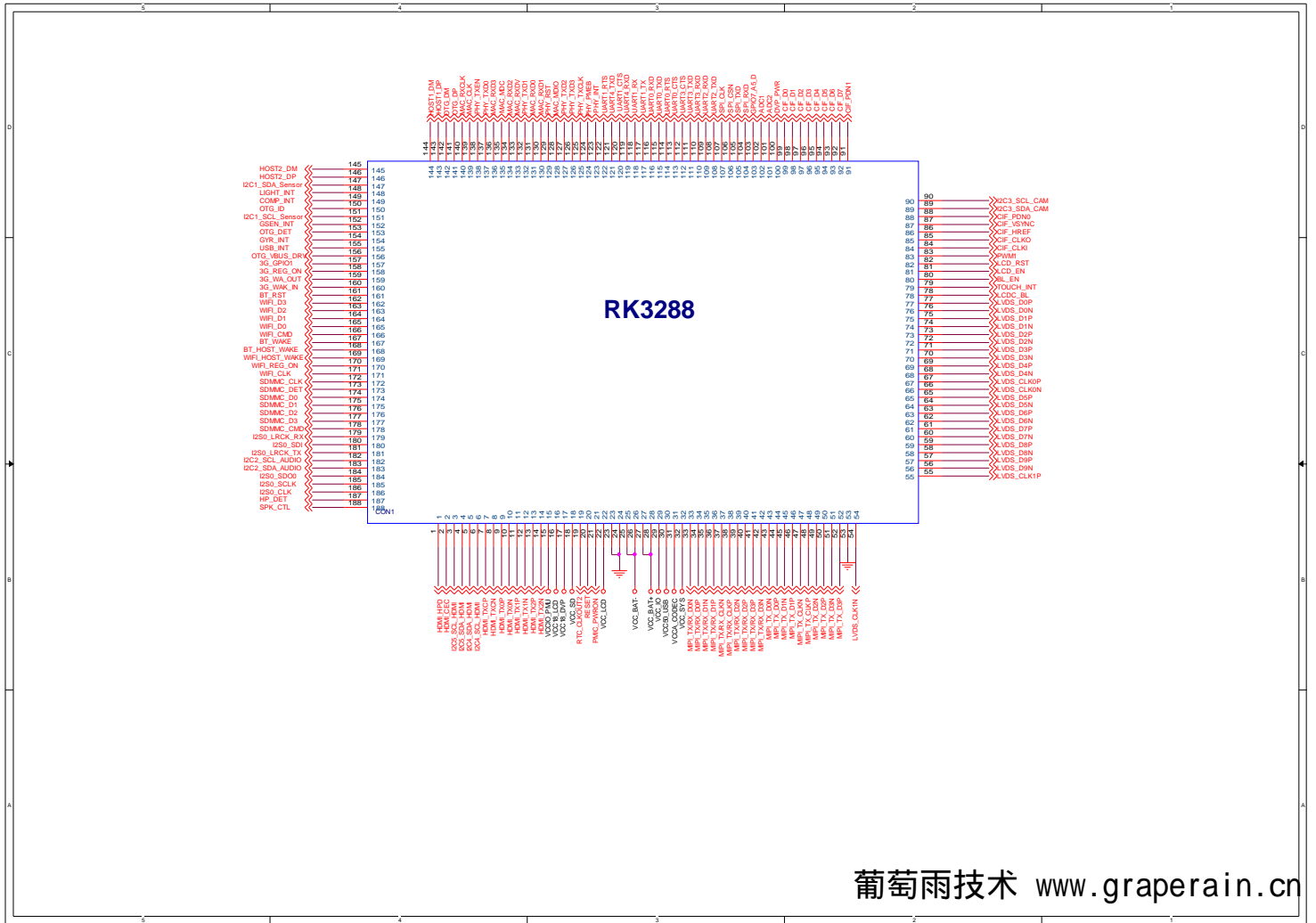

葡萄雨技术 www.graperain.cn

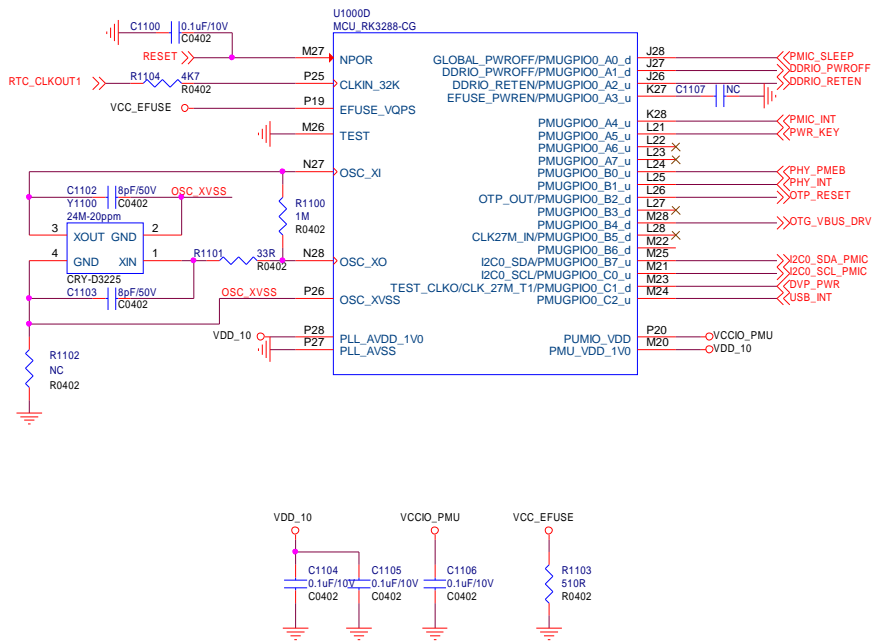

Note: All the capacitor should be place close to the power pin of RK3288-CG.

Title: RK3288-CG PMU Controller		
File: RK3288-CG_VR_REF	REV: V1.0	
Create Date: Thursday, February 13, 2014	Page Num: 11	
Modify Date: Tuesday, August 30, 2016	Page Total: 84	

DDR3 Channel-0

DDR3 Channel-1

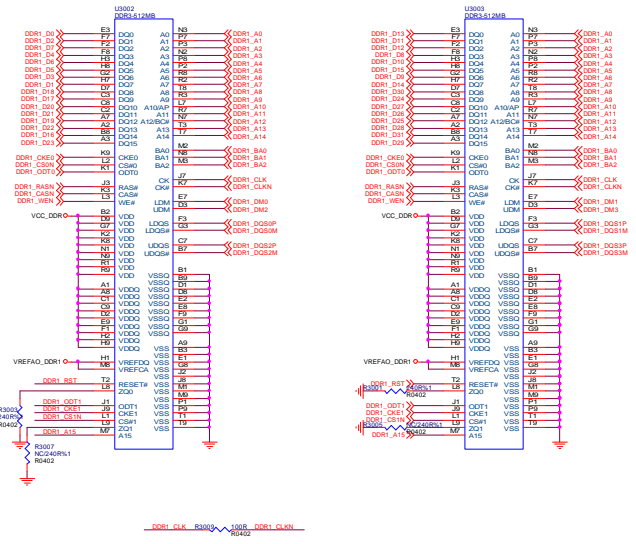

DDR0 FILTER

DDR1 FILTER

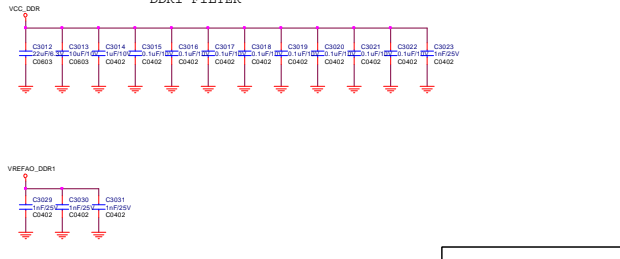
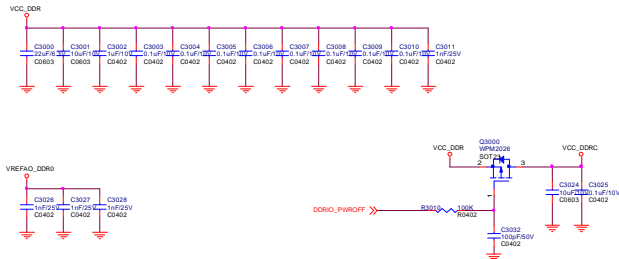

Title: RAM-DDR3 4x16G1E	
File: RK3888-CG_VR_REF	
Created Date: Wednesday, February 26, 2014	Page: Num: 35
Modify Date: Tuesday, August 30, 2016	Page: Total: 84